

High-speed composite (HSC) gearbox

Weight reduction is a dominant factor in improving fuel efficiency. Then, it might be accomplished by lightweight materials (e.g. Magnesium, aluminum and carbon fiber reinforced composite (CFRP)) and optimal structural design. In this collaboration, we would like to develop composite gearbox system. In particular, we consider high-speed gearbox system for high performances of electric vehicle (EV). Those details are presented below:

1. Objectives: Development of composite gearbox for Electric vehicle (EV)

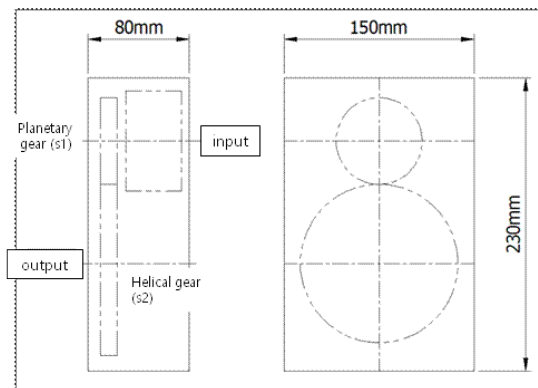

<EV (left) and Schematic outline (right)>

2. Spec

- Maximum input speed/torque: 14,000 rpm / 75 Nm
- Reduction gear ratio: 1/9
- 2 stage gear (stage 1: planetary gear, stage 2: helical gear)
- Weight: over 20% weight reduction compared with classical steel materials
- Housing materials: carbon fiber reinforced composite (CFRP)

3. Research topics

- 1) Design, analysis and manufacturing of CFRP and hybrid housing
- 2) Design of lubrication system with high-speed gearbox
- 3) Design of high-speed geartrain including acceptable bearing
- 4) Fatigue and reliability test & evaluation of CFRP housing

5. Partners in South Korea (1 National lab and 2 companies)

- Korea Institute of Machinery and Materials
- HYUNDAI MOBIS (R&D Division)
- SAMYANG reduction gear Co. LTD.

4. Contact info.

Jin-Gyun Kim Ph.D./Senior researcher, Korea Institute of Machinery and Materials (KIMM), +83-42-868-7464, jingyun@kimm.re.kr

Jeongdai Jo Ph.D./NCP-NMP, Korea Research&Innovation Centre-Europe (KIC-Europe), +32 (0)2 880 39 11, jedai.jo@kiceurope.eu / micro@kimm.re.kr